



Topper Stand Assembly

- Topper Stands are offered in multiple size
- Select the stand that matches:
 - the width of your table toppers

AND

 - has the quantity of slots = the quantity of toppers
- Assembly is the same across all sizes.
- Parts list, critical steps & assembly instructions to follow.
- Be sure to watch our accompanying assembly video too!



Parts List

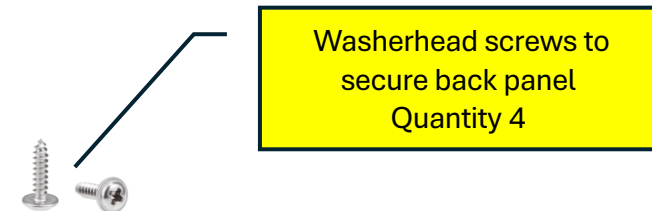
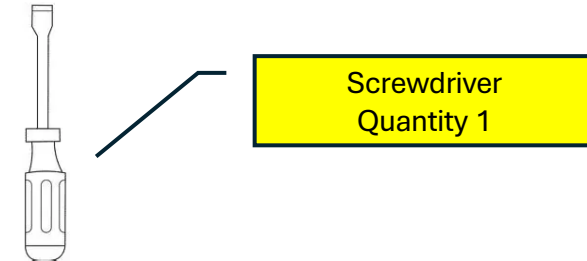
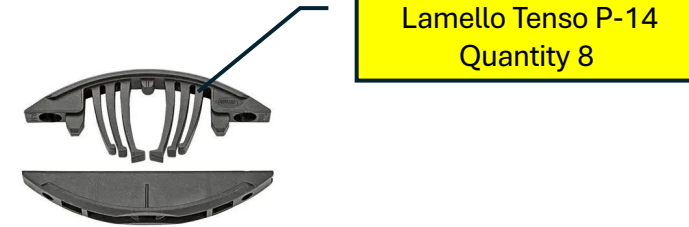
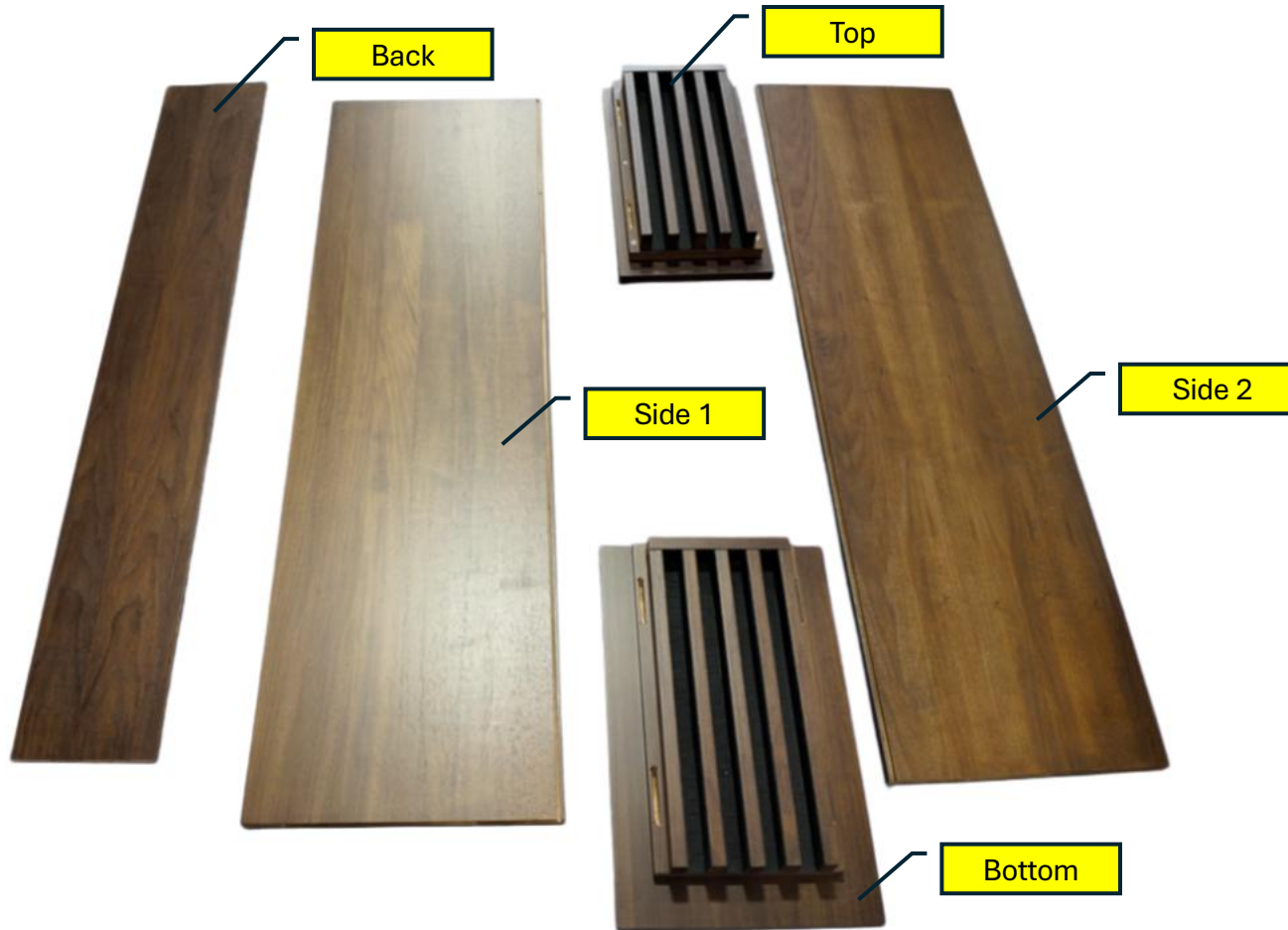



Two critical things to understand before starting assembly

- Critical item #1. The sides must have the slots facing in and to the back of the stand when installed
- Critical item #2. Ensure the top and bottom are facing the correct way before attaching them to the side panels

<<<Illustrations to follow>>>

Critical Item #1





Critical Item #2

Open slots on the
base and top face
front!



Assembly step #1 Lamello™ Spring Clips into the side panel slots

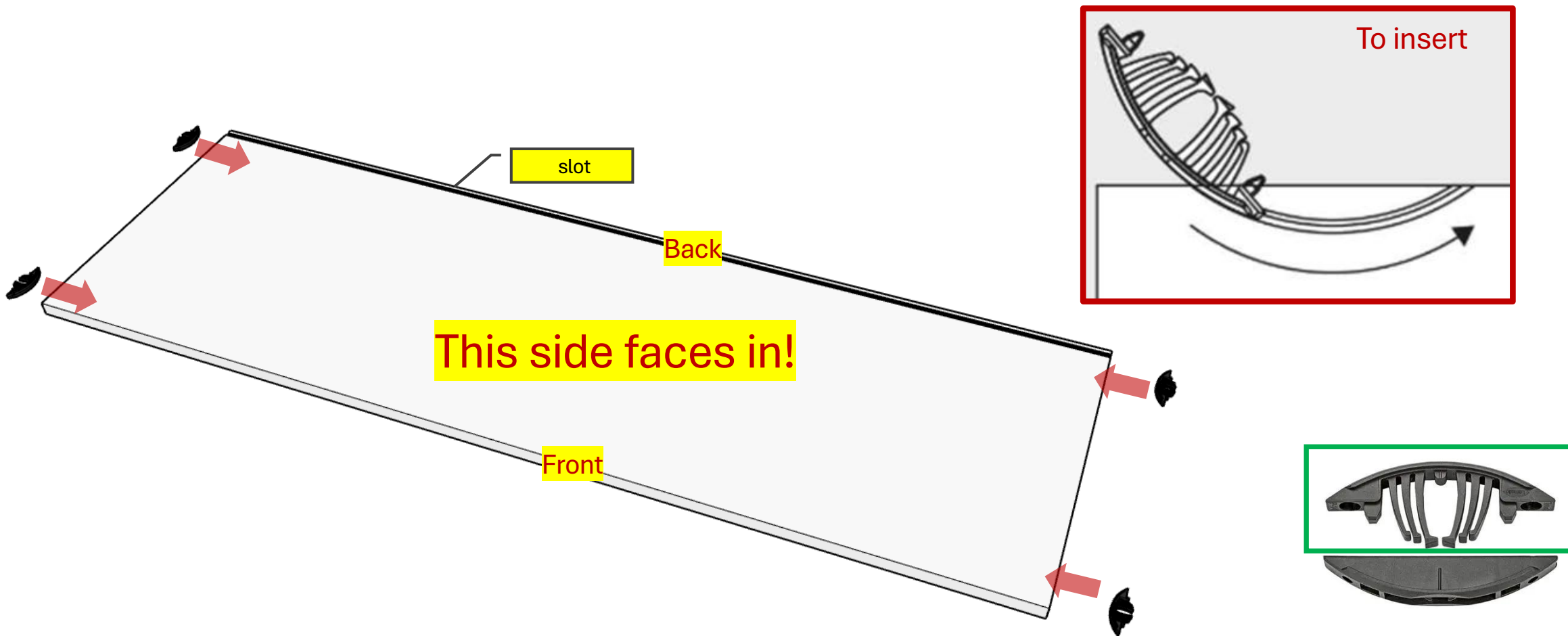

Assembly step #2 Lamello™ receiving slots into the base & top

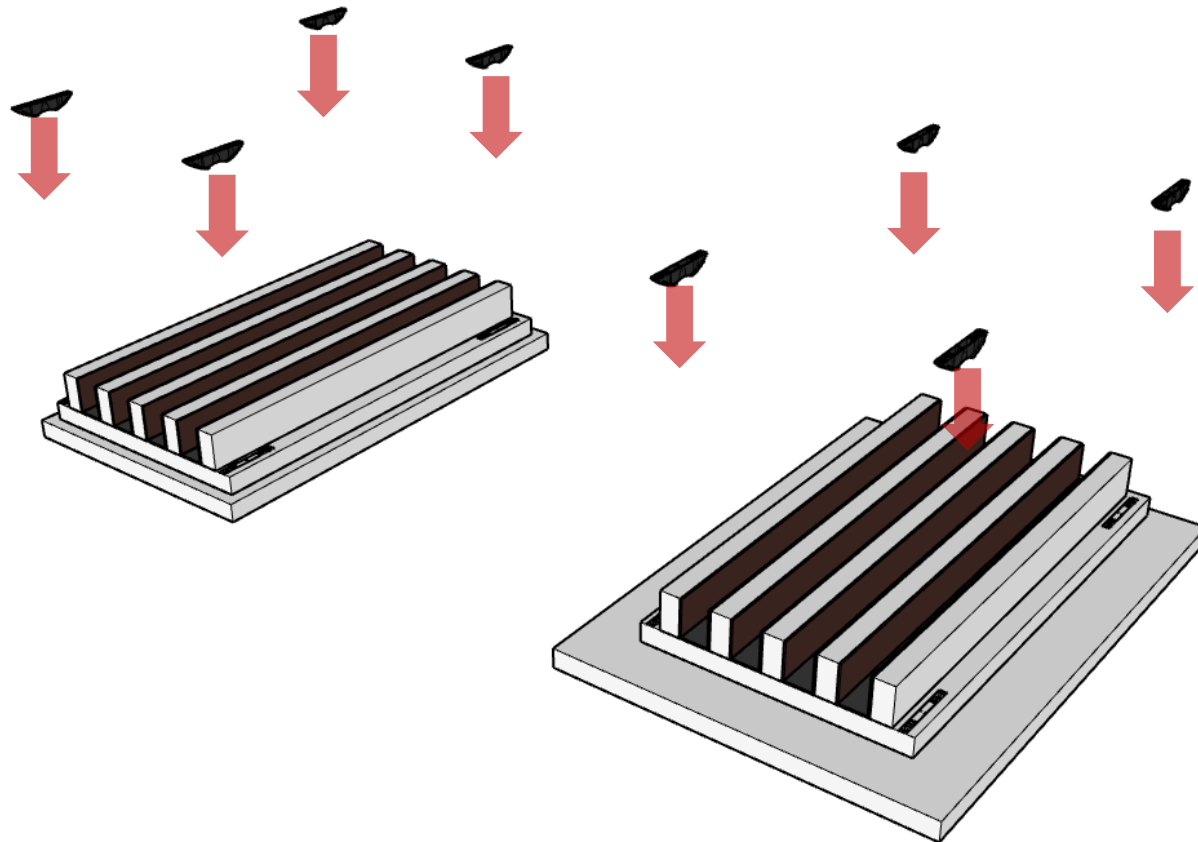

Assembly step #3 **Sides click into the base**

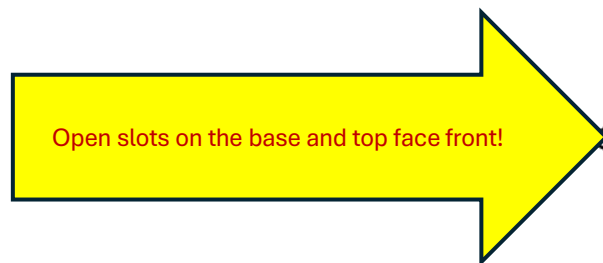
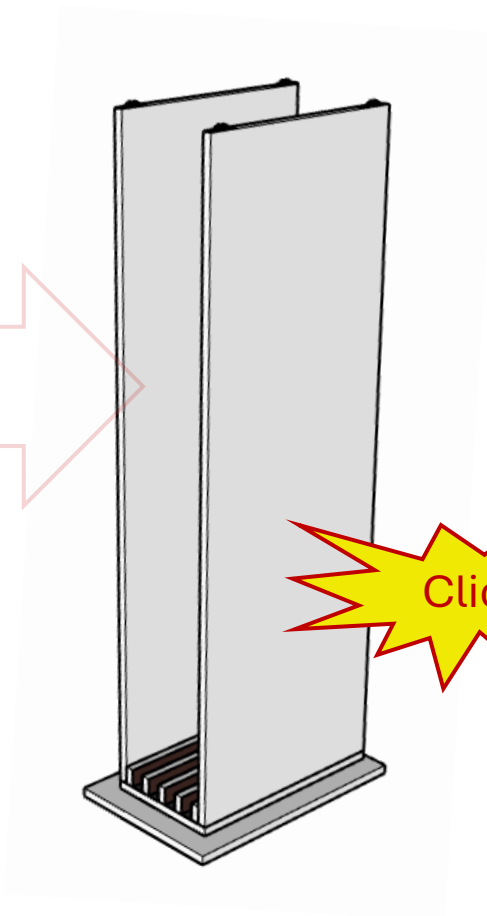
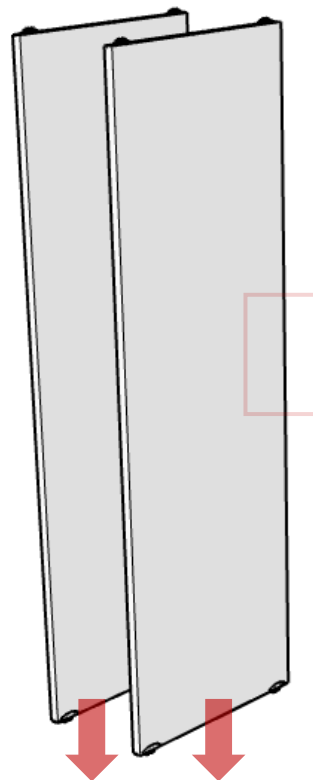

Trouble?
make sure the Lamello fittings are
aligned on center with one-
another so the spring fitting
spreads over the posts inside the
opposing fitting

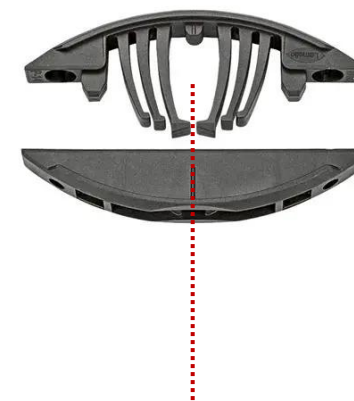

Assembly step #4

Rear panel slides into the groove

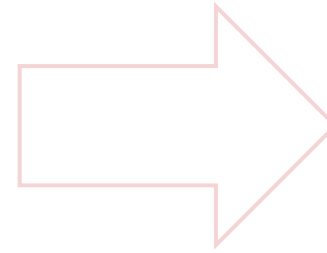
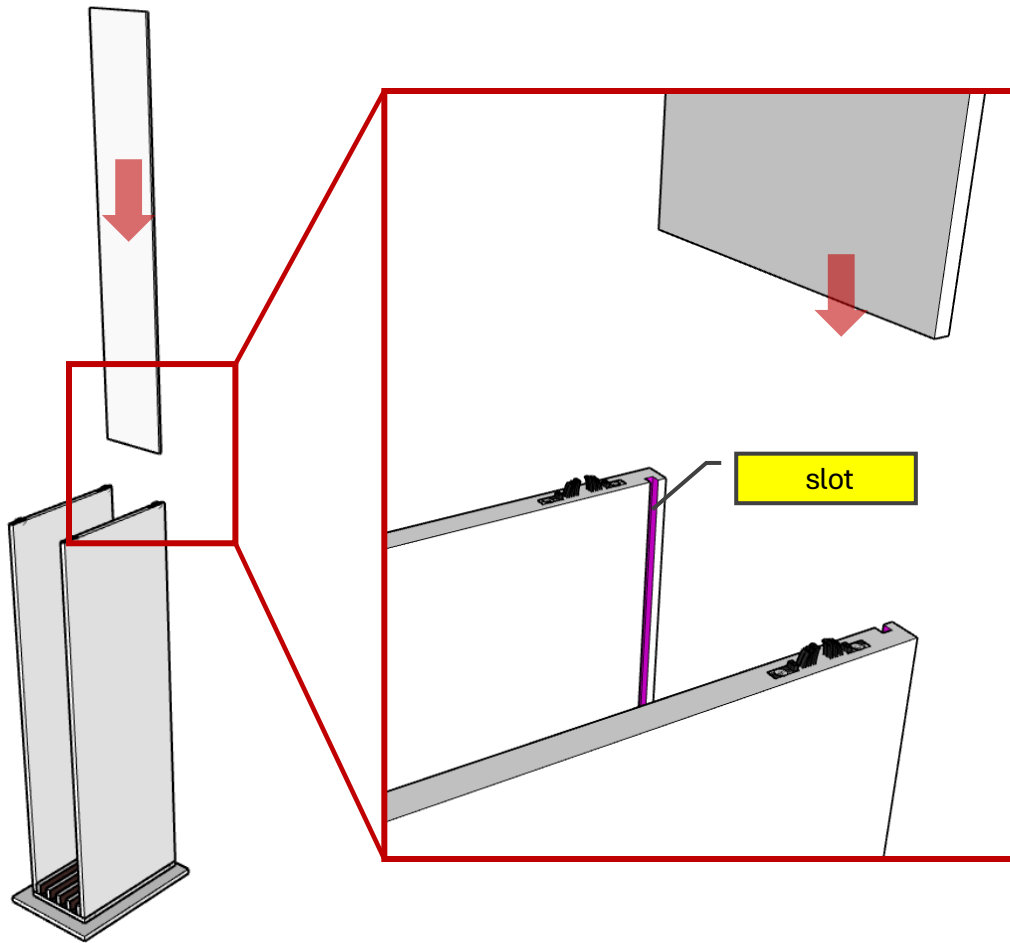

**Ensure panel fully seated in slot
from top to bottom**

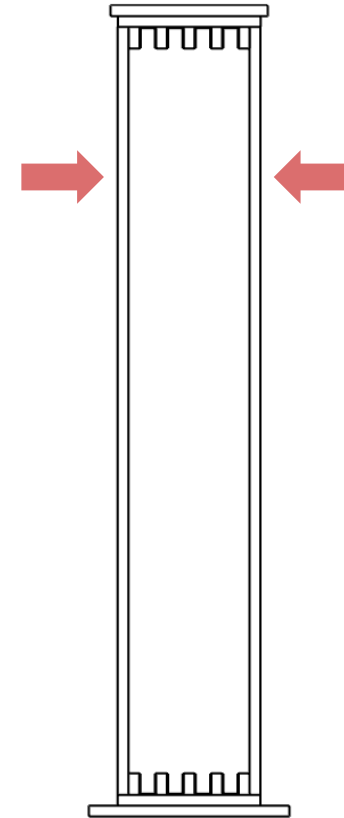

Assembly step #5 Top clicks onto side panels

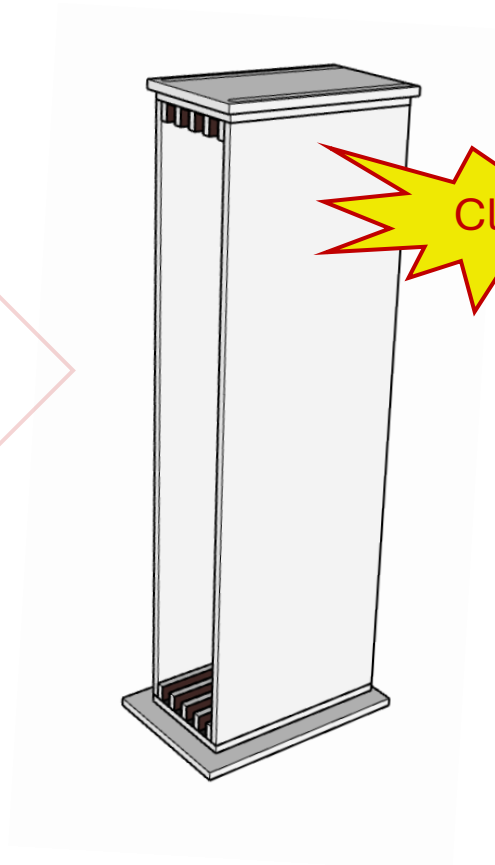
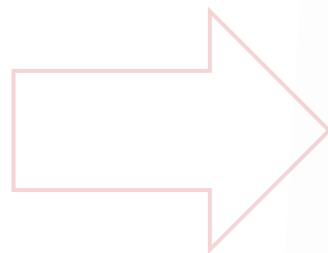
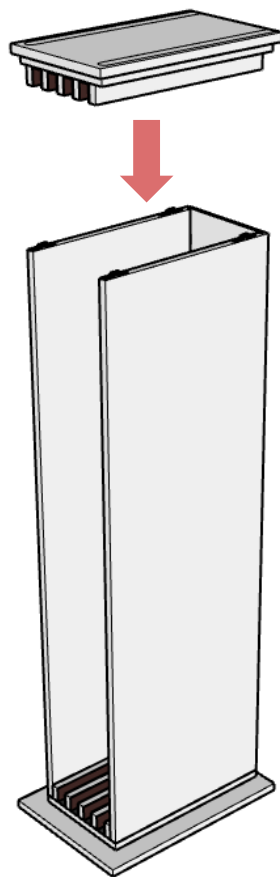

Trouble?
make sure the Lamello fittings are aligned on center with one-another so the spring fitting spreads over the posts inside the opposing fitting

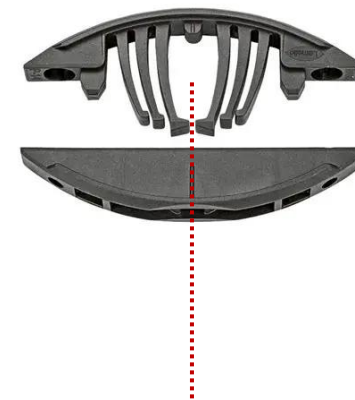



Assembly step #6 **Attach provided screws**

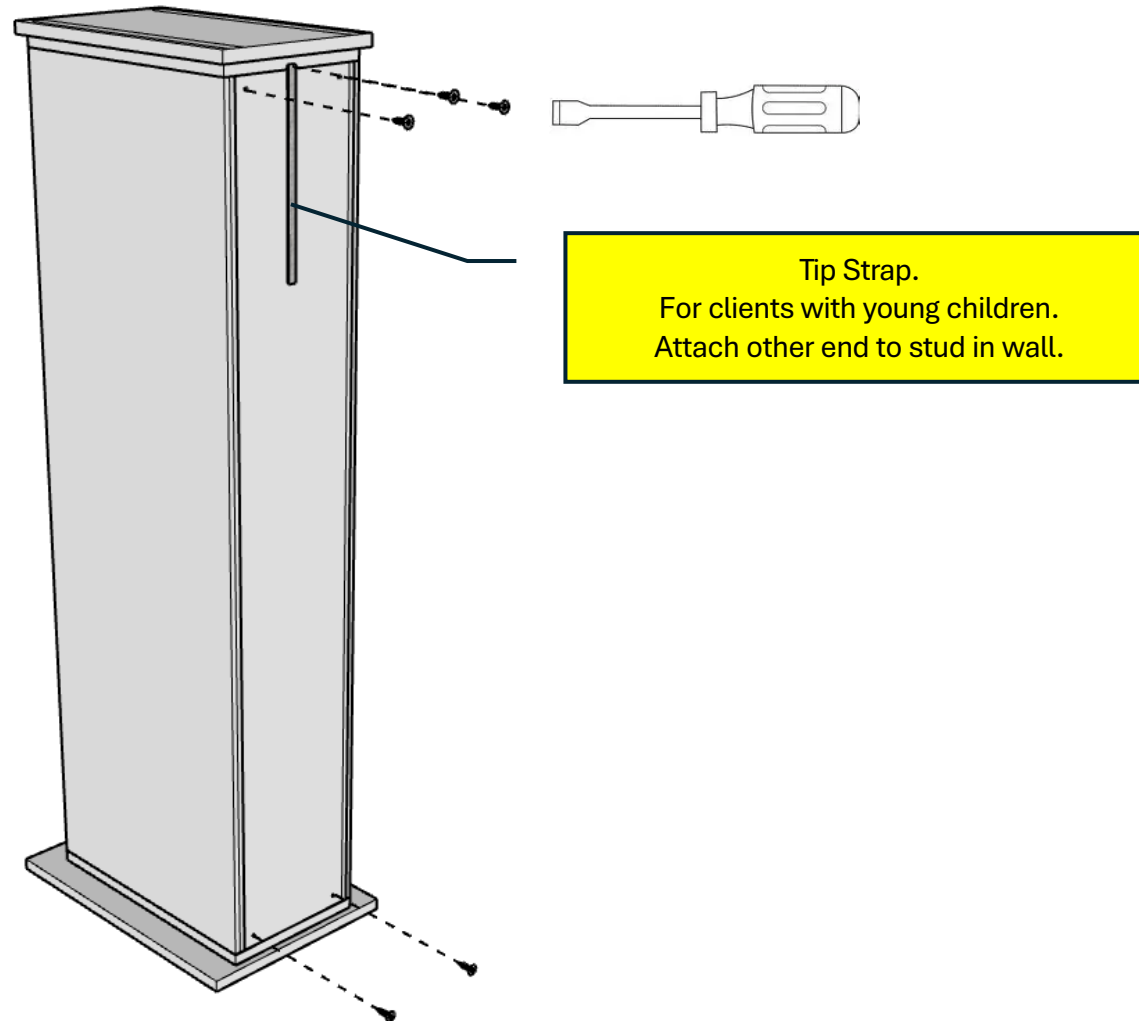



Assembly step #7 **Toppers stored, Done!**

